

Hydraulics & pneumatics

A Penton Publication

SERVING FLUID POWER AND MOTION CONTROL ENGINEERS WORLDWIDE



Hydraulics
with
curb
appeal

www.hydraulicspneumatics.com

Slipform paver uses rotary actuator to combine Power with Precision

Slipform paver offers turning radius of less than 2 ft for increased worksite versatility and efficiency.

By incorporating helical, hydraulic rotary actuators to steer the four tracks on its Easi-Pour Compact 880 slipform paver, Huron Mfg. was able to provide its customers with a machine that accomplishes what used to require multiple machines. This compact machine can be used for large or small jobs ranging from tight radius curbs, gutters, and sidewalks to surface grade preparation and trimming. “Our customers are impressed with what this Easi-Pour can do — which is essentially everything. They can buy the less expensive Easi-Pour, yet get the same versatility found in larger slipform pavers,” explains Murray Serfling, engineering manager at Huron Mfg. “While it’s rare that a contractor attempts a radius as tight as two feet, this machine can actually turn and hold grade even tighter than that.”

The Easi-Pour in action

The Easi-Pour Compact 880 pours barriers to 42 in. high, paves up to 8 ft widths, and handles any tasks that fall in between these specifications. After an accompanying transit mixer pours concrete mixture into its conveyor hopper, the Easi-Pour’s auger moves material across the machine to a slipform mold that’s located at road level. As the paver travels forward, a hydraulic vibrator helps shape the



concrete in a mold, guided by a string-line sensing system also manufactured by Huron. The stringline system automatically ensures perfect steering and grade by incorporating five sensors — two steering, two grade, and one cross-level control. The 880 machine also comes with a grade trimmer with a standard width of 51 in. to trim high spots from the road surface.

Huron's Easi-Pour matches up well against industry alternatives. In addition to the tighter turning radius, this low-profile machine provides the operator excellent visibility of all the machine's operations. It features the



Even if Helac's L-30 series rotary actuator didn't provide a simpler, more compact design than conventional steering cylinder assemblies, its steering angle is more than twice that of cylinders — still making it an attractive alternative.

industry's largest concrete hopper, yet requires no breakdown for transport. All Easi-Pours feature 4-leg stability, and all legs are capable of hydraulically 'sliding' to accommodate essentially any paving configuration. Most importantly, safety, durability, and long life are engineered into every Easi-Pour.

Fully hydraulic operation

The Easi-Pour Compact 880 is entirely hydraulically operated and does not come with any mechanical drives. Hydraulics in the form of helical, hydraulic rotary actuators are used to operate its four-track steering system. The actuators are rated to 3,000 psi. The four tracks are driven hydraulically through two-speed piston motors — low speed during forming operations, and high speed for travel around the job site.

The track drives are rated at 4,500 psi with total flow of 49 gpm. The hydraulic driver trimmer drive uses a closed-circuit piston pump operating at pressure to 4,500 psi, with flow to 36 gpm. The machine's conveyor and hopper auger are driven by a gear pump with a manual hand valve to regulate speed. The conveyor and hopper's operating pressure is 2,500 psi, requiring up to 25 gpm flow from the gear pump. Elevation and steering pressures of the machine top out at 2,200 psi, supplied by a pressure-compensated, open-circuit pump. 12-V solenoid valves are used to control all the functions performed by the pressure-compensated pump.

Critical issues solved

Huron Mfg. replaced the previously used steering cylinders with Helac Corporation's sliding spline rotary actuator technology to solve the issues that were inherent with the hydraulic cylinders.

The cylinders offered a turning radius of only 60° — 30° left and 30° right — compared to the 180° of

rotation offered by the rotary actuator. The former steering configuration also required multiple mechanical linkage components that needed to be machined and welded together, which is inherent to this type of design. The rotary actuator technology offers a cylindrical housing that contains all moving parts safely inside. The rotary actuators not only became the steering unit for all four tracks, but provide the support of the load and the hydraulic turning power as well.

Huron Mfg. also had maintenance and machine performance issues with the steering cylinders from all the pivot pins and also the pins to keep bearings mounted between caster plates. The machine operators needed to make sure the pins were kept tight, and the bearings had to be greased regularly. The machine wouldn't operate properly if the pins holding the bearing loosened. Helac's bearings, seals, and torque-generating elements all are completely sealed and lubricated by the hydraulic fluid inside the actuator housing, resulting in low maintenance and zero leakage.

The use of mechanical drives — chains and linkages — with the cylinders also limited the vertical and horizontal positioning of the tracks. However, the rotary actuators provide steering feedback through a transducer mounted at the end of each actuator.

Additional benefits

The advantages of the actuator technology go far beyond eliminating the cylinder steering. "We've used Helac's actuators for two other machines in the past, including our milling and mining machines for 4-wheel steering and conveyor positioning. Helac's products continue to be durable and reliable, and are incredibly easy to design into any of our machines," explains Serfling.

Helac actuators improved the overall appearance of the Easi-Pour

Actuator operation technology

Operating technology is the key to the benefits of Helac's hydraulic rotary actuator. Its design affords a unique combination of features not found in other rotary positioning components — high torque and moment loads, high angles of rotation, and compact configurations.

Helac's sliding-spline operating technology is designed to replace multiple components and function as a rotating device, mounting bracket, and bearing, all in one.

Helac's design converts linear piston motion into powerful shaft rotation. Each actuator is composed of two moving parts — a central shaft and piston. Helical spline teeth on the shaft engage matching teeth on the piston's inside diameter. When hydraulic pressure is applied to the piston, it moves axially, while the splines cause the piston and output shaft to rotate simultaneously.

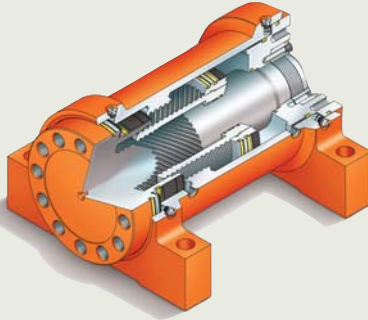

the Easi-Pour machine the power to make much tighter turns than many comparable machines in the industry. The quality of the pour also improved because the height of the drive tracks could be independently controlled without impacting the steering capability.

Serfling concludes, "The rotary actuators we are using to steer the front two tracks 180° are Helac's L30-95-E-FF-180 product model. The back two tracks use the same product model, but they're fitted with an internal stop to limit rotation to 100°." The actuator supports 10,000 lb of thrust and provides 261,250 lb-in. of moment capacity. Steering torque is 55,000 lb-in. at 2,000 psi when fully loaded.

880 machine with their clean package that's compact and doesn't interfere with other functions. Improved performance of the slipform paver

was an additional benefit of the rotary actuator.

The torque output generated by Helac's L30 Series actuator gave

For information, contact lmorgan@helac.com or visit www.helac.com.

For more information on Huron Mfg. visit www.huronmanufacturing.com.

Copyright © 2010 by Penton Media, Inc



HELAC CORPORATION

225 Battersby Avenue
Enumclaw, WA 98022 USA
Toll-free +1 800 327 2589
Telephone +1 360 825 1601
Fax +1 360 825 1603
www.helac.com